

**Bait Tank Data**  
 Overall Width = 3'-4"  
 Overall Length = 6'-0"  
 Overall Height = 2'-8"  
 Overall Depth = 1'-9 1/4"  
 Unit Weight = 126 lbs.  
 Water Capacity = 195 Gallons  
 Available Color  
 Blue

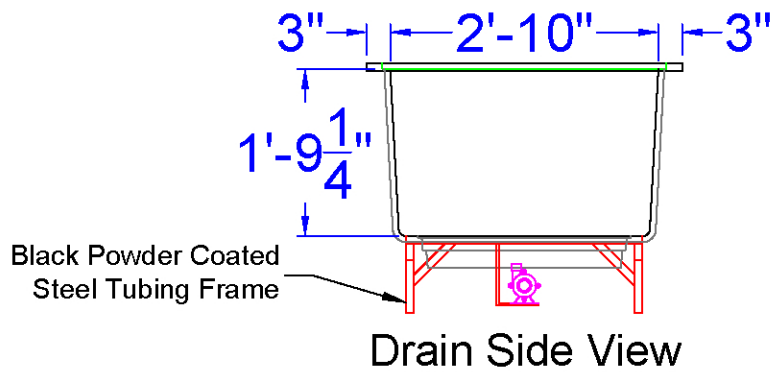

**PIEDMONT**  
 COMPOSITES & TOOLING

33 Lewittes Rd.  
 Taylorsville, NC 28681  
 Phone: 828-632-8883  
 Fax: 828-632-5585  
 www.Piedmontcomposites.com

**BAIT-TANK**

Model:  
**650-W-FILTER-CHILLER**

Scale:  
 SCALE  
 Drawn by:  
 JEM  
 Created On  
 12/17/12  
 Updated On  
 04/03/19