

Bait Tank Data
 Overall Width = 3'-4"
 Overall Length = 8'-0"
 Overall Height = 2'-8"
 Overall Depth = 1'-9 1/4"
 Unit Weight = 162 lbs.
 Water Capacity = 267 Gallons
 Available Color
 Blue

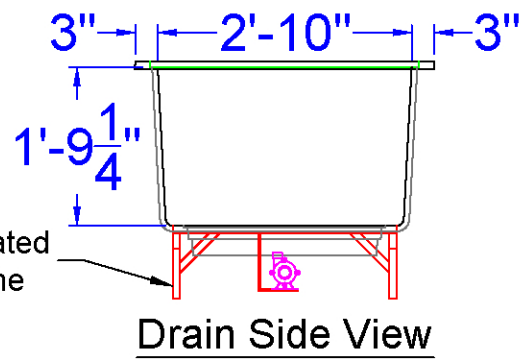

33 Lewittes Rd.
 Taylorsville, NC 28681
 Phone: 828-632-8883
 Fax: 828-632-5585
 www.Piedmontcomposites.com

BAIT-TANK

Model : **850-W-FILTER-CHILLER**

Scale:
SCALE
 Drawn by:
JEM
 Created On
12/17/12
 Updated On
04/03/19

Note: All drawings are the property of Piedmont Composites & Tooling, LLC. Variation in material thickness, dimension and weight may occur. PCT reserves the right to change or modify design at anytime without notice.